

HORIZONTAL PADDER TYPE «HF»

Lab samples padding

This 2-roll padder is built as a table model and has been developed especially for the Chemical, Textile and Dyestuff Industry, for Finishing Works and Research Institutes.

The unit can be used for dyeing, impregnating and finishing of textiles such as fabrics, knitwear, non-wovens, ribbons, felt etc.

The padder type «HF», together with our laboratory dryer type «LTE» or laboratory steamer type «DH», form an ideal combination for your laboratory.



www.mathisag.com

Adapted to the production

Dipping time and squeezing pressure are adjustable so that the usual common pick up values from production can be achieved.

Option

- Up and unwinding device for padding of longer samples
- A set of gear wheels for the drive of both rollers
- Alkaline resistant roller coverings (recommended for cold pad-batch dyeing processes with high alkaline concentrations)
- Distance adjusting device
- automatic pressure release when the rollers are stopped
- Under carriage with rolls and brake
- Suitable compressor for compressed air

Technical information

Roller width:	350 mm
Working width:	300 mm
Roller diameter:	110 mm
Roller speed:	2 - 10 m/min
Air connection:	max. 6 bar
Linear pressure:	max. 300 N/cm
Nip liquor content:	~250 ml
Weight:	~130 kg

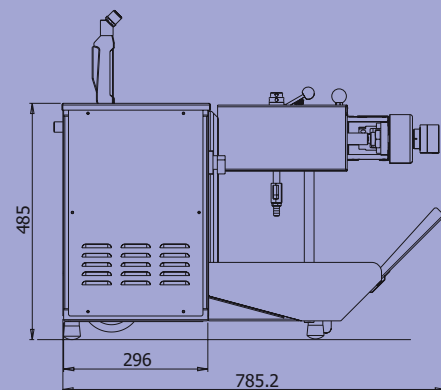
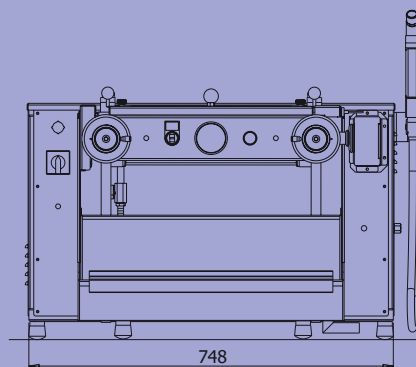

Werner Mathis AG

Rütisbergstrasse 3
CH-8156 Oberhasli/Zürich, Switzerland
Telefon: +41 44 852 50 50
Telefax: +41 44 850 67 07
info@mathisag.com
www.mathisag.com

Werner Mathis U.S.A. Inc.

2260 HWY 49 N.E./P.O. Box 1626
Concord N.C. 28026, U.S.A.
Phone: +1 704 786 6157
Fax: +1 704 786 6159
usa@mathisag.com

Mathis (India) PVT. LTD.

No.01, Shreeji Arcade
1st Floor, Opp. Nitin Co.
Almeida Road, Thane 400 602
Phone/Fax: +91 22 2538 5472
india@mathisag.com

Aparelhos de laboratorio Mathis Ltda

Estrada dos Estudantes 261
CEP 06707-050 COTIA S.P., Brasil
Phone: +55 11 3883 6777
Fax: +55 11 3883 6750
brasil@mathisag.com